

MODEL QTXE110S VENTILATOR

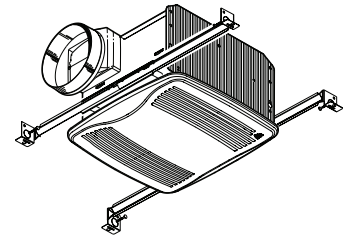

A modern-styled, high performance fan, with sensing circuitry, that “knows” when to ventilate the room.

FEATURES

BLOWER:

- Plug-in, permanently lubricated motor - engineered for continuous operation
- Dynamically balanced centrifugal blower wheel for quiet, efficient performance
- Maintains a high percentage of rated CFM in less than ideal installations
- Low RPM for quiet operation

HOUSING:

- Rugged, 26 gauge, galvanized steel construction
- 6” round ducting for superior performance
- Polymeric duct connector with tapered sleeve and no metallic clatter
- 7-5/8” height allows for 2” x 8” (nominal) joist installations
- Sturdy, easy, four-point mounting directly to joist
- Includes unique spacer (patent pending) for mounting to engineered “I” joists
- Includes hanger bars to position housing anywhere between 16” to 24”-on-center joists
- Two sets of mounting holes for hanger bars allow flush installation with bottom or top of drywall

GRILLE:

- Integrated humidity sensor
- Polymeric construction
- Innovative design - the result of extensive research with designers and consumers

AUTOMATIC CONTROL:

- Humidity control automatically turns fan ON when either of these conditions is detected:
 - a rapid to moderate (user adjustable) increase of humidity
 - humidity above user-adjustable set-point (50%-80% RH)
- Two wire manual operation for odor control - Turns fan ON when power line through wall switch is cycled ON, OFF and back ON
- Remains ON for a user-adjustable 5 to 60 minutes after humidity has stabilized and is below set-point or after manually initiated through power line cycling
- Saves energy because unit runs only for the time required. A unit controlled with a wall timer may keep fan ON longer than required or turn it OFF before room is sufficiently ventilated

ACCESSORY CONTROL (Purchase separately):

Designed by Broan for use with this product (purchase separately)

- Model 68V, P68V (Ivory) / 68W (White) 2-Function Wall Control

U.L. Listed for use over bathtubs and showers when connected to a GFCI protected branch circuit (ceiling mount only).

3-Year Warranty



Broan-NuTone LLC Hartford, Wisconsin www.broan.com 800-558-1711

REFERENCE	QTY.	REMARKS	Project
			Location
			Architect
			Engineer
			Contractor
			Submitted by Date

TYPICAL SPECIFICATION

Ceiling Ventilator shall be Broan Model QTXE110S.

The unit will have a control that will automatically turn fan ON when humidity increase is rapid to moderate (user adjustable), or when humidity is higher than user-adjustable set-point (50%-80% Relative Humidity), or when supply power is cycled from ON (for more than a second) to OFF (for less than a second) and back ON. It shall be user-adjustable to turn OFF 5 to 60 minutes after humidity has stabilized and is below user-adjustable set-point, or after manually initiated by supply power cycling.

Ceiling Ventilator shall have corrosion resistant galvanized steel housing with four-point mounting capability. It shall be ducted to a roof or wall cap using 6" round ductwork.

Blower assembly shall be removable, have a centrifugal-type blower wheel and a permanently lubricated motor designed for continuous operation.

Non-metallic damper/duct connector shall be included.

Air delivery shall be no less than 110 CFM and sound level no greater than 0.7 Sones. All air and sound ratings shall be certified by HVI.

Ceiling Ventilator shall be Energy Star® qualified and have an energy efficient permanent split capacitor motor.

Ceiling Ventilator shall be U.L. Listed for use over bathtubs and showers when connected to a GFCI protected branch circuit.

PERFORMANCE RATINGS MODEL QTXE110S VENTILATOR

HVI PERFORMANCE

Model	Static Pressure (Ps)	CFM	Sones	Fan Watts
QTXE110S	0.10	110	0.7	33.5
	0.25	90		



HVI-2100 CERTIFIED RATINGS comply with new testing technologies and procedures prescribed by the Home Ventilating Institute, for off-the-shelf products, as they are available to consumers. Product performance is rated at 0.1 in. static pressure, based on tests conducted in a state-of-the-art test laboratory. Sones are a measure of humanly-perceived loudness, based on laboratory measurements.

AMPS

Model	Amps*
QTXE110S	0.3

* Total connected load

WEIGHT

Model	Shipping Weight
QTXE110S	12.2 lbs.

AIR FLOW PERFORMANCE

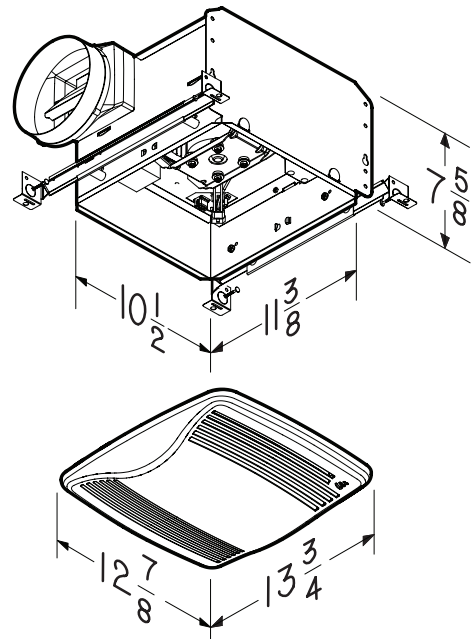
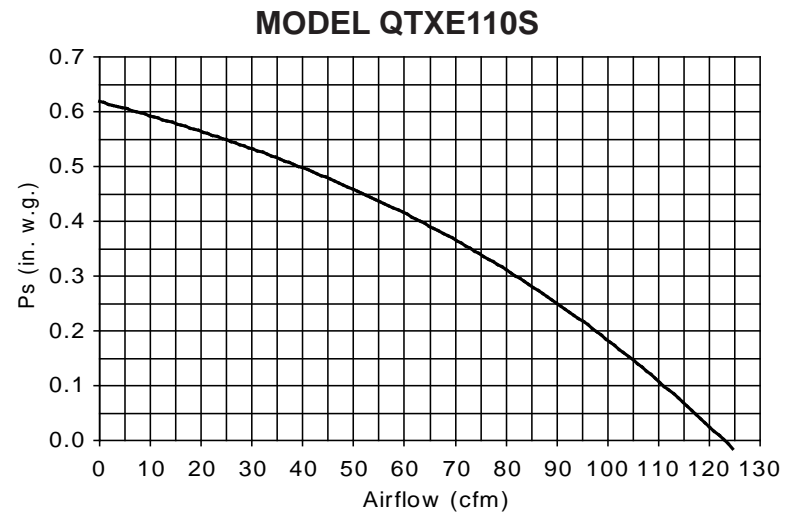

BROAN

Broan-NuTone LLC Hartford, Wisconsin www.broan.com 800-558-1711

MODEL QTXE110S VENTILATOR

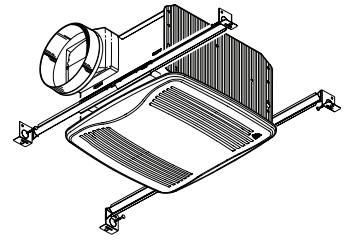

A modern-styled, high performance fan, with sensing circuitry, that “knows” when to ventilate the room.

FEATURES

BLOWER:

- Plug-in, permanently lubricated motor - engineered for continuous operation
- Dynamically balanced centrifugal blower wheel for quiet, efficient performance
- Maintains a high percentage of rated CFM in less than ideal installations
- Low RPM for quiet operation

HOUSING:

- Rugged, 26 gauge, galvanized steel construction
- 6” round ducting for superior performance
- Polymeric duct connector with tapered sleeve and no metallic clatter
- 7-5/8” height allows for 2” x 8” (nominal) joist installations
- Sturdy, easy, four-point mounting directly to joist
- Includes unique spacer (patent pending) for mounting to engineered “I” joists
- Includes hanger bars to position housing anywhere between 16” to 24”-on-center joists
- Two sets of mounting holes for hanger bars allow flush installation with bottom or top of drywall

GRILLE:

- Integrated humidity sensor
- Polymeric construction
- Innovative design - the result of extensive research with designers and consumers

AUTOMATIC CONTROL:

- Humidity control automatically turns fan ON when either of these conditions is detected:
 - a rapid to moderate (user adjustable) increase of humidity
 - humidity above user-adjustable set-point (50%-80% RH)
- Two wire manual operation for odor control - Turns fan ON when power line through wall switch is cycled ON, OFF and back ON
- Remains ON for a user-adjustable 5 to 60 minutes after humidity has stabilized and is below set-point or after manually initiated through power line cycling
- Saves energy because unit runs only for the time required. A unit controlled with a wall timer may keep fan ON longer than required or turn it OFF before room is sufficiently ventilated

ACCESSORY CONTROL (Purchase separately):

Designed by Broan for use with this product (purchase separately)

- Model 68V, P68V (Ivory) / 68W (White) 2-Function Wall Control

U.L. Listed for use over bathtubs and showers when connected to a GFCI protected branch circuit (ceiling mount only).

3-Year Warranty



Broan-NuTone LLC Hartford, Wisconsin www.broan.com 800-558-1711

REFERENCE	QTY.	REMARKS	Project
			Location
			Architect
			Engineer
			Contractor
			Submitted by Date

TYPICAL SPECIFICATION

Ceiling Ventilator shall be Broan Model QTXE110S.

The unit will have a control that will automatically turn fan ON when humidity increase is rapid to moderate (user adjustable), or when humidity is higher than user-adjustable set-point (50%-80% Relative Humidity), or when supply power is cycled from ON (for more than a second) to OFF (for less than a second) and back ON. It shall be user-adjustable to turn OFF 5 to 60 minutes after humidity has stabilized and is below user-adjustable set-point, or after manually initiated by supply power cycling.

Ceiling Ventilator shall have corrosion resistant galvanized steel housing with four-point mounting capability. It shall be ducted to a roof or wall cap using 6" round ductwork.

Blower assembly shall be removable, have a centrifugal-type blower wheel and a permanently lubricated motor designed for continuous operation.

Non-metallic damper/duct connector shall be included.

Air delivery shall be no less than 110 CFM and sound level no greater than 0.7 Sones. All air and sound ratings shall be certified by HVI.

Ceiling Ventilator shall be Energy Star® qualified and have an energy efficient permanent split capacitor motor.

Ceiling Ventilator shall be U.L. Listed for use over bathtubs and showers when connected to a GFCI protected branch circuit.

PERFORMANCE RATINGS MODEL QTXE110S VENTILATOR

HVI PERFORMANCE

Model	Static Pressure (Ps)	CFM	Sones	Fan Watts
QTXE110S	0.10	110	0.7	33.5
	0.25	90		



HVI-2100 CERTIFIED RATINGS comply with new testing technologies and procedures prescribed by the Home Ventilating Institute, for off-the-shelf products, as they are available to consumers. Product performance is rated at 0.1 in. static pressure, based on tests conducted in a state-of-the-art test laboratory. Sones are a measure of humanly-perceived loudness, based on laboratory measurements.

AMPS

Model	Amps*
QTXE110S	0.3

* Total connected load

WEIGHT

Model	Shipping Weight
QTXE110S	12.2 lbs.

AIR FLOW PERFORMANCE

