



Catalog Number
Notes
Type

Contractor Select™ EAX1/EAX2 LED Area Luminaire

The EAX provides the best combination of switchable technology including adjustable lumens, switchable CCT color temperature and exclusive four-optic SwitchOptics™ providing Type II, III, IV and V distribution patterns; all from the same luminaire. This vast feature-set allows maximum versatility while managing the lowest possible SKUs required for site and pole mount lighting.

FEATURES:

- EAX1 provides 5,000 to 16,000 lumens (50-250W and 400W replacement)
- EAX2 provides 18,000 to 30,000 lumens (400W to 1000W replacement)
- Each luminaire provides over 60 in-field configurations with the broadest array of switchable technology combined with (UPM) universal mounting.
- Easy access switching features Adjustable light output (ALO), switchable CCT (SWW2) and switchable optics (SO) including Type II, III, IV and V distributions.
- UPM universal pole mount with tilt for round and square poles, includes 2 3/8" built in pole top tenon fitter. (fits 3.5" min SQ and 3" min dia. RND side mount, 2 3/8" OD pole top tenon)
- All luminaires are sensor-ready and include a PER 3-pin NEMA twistlock photocell receptacle with shorting cap and Acuity twist-to-lock sensor receptacle.

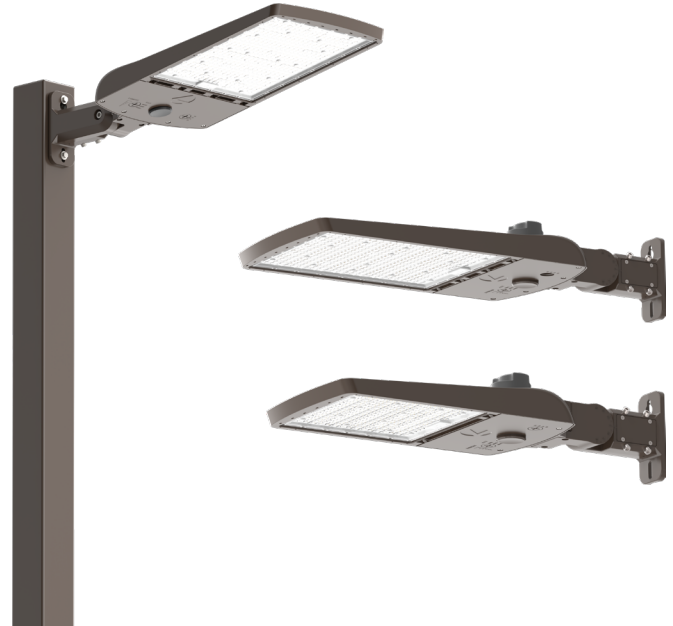

Catalog	Lumens *(set on max)	Watts *(set on max)	CCT *(set on 40K)	Optics *(set on T3)	Voltage	Mounting Type	Finish	CI Code	UPC	Pallet Qty
EAX1 ALO SWW2 SO UVOLT UPM PER DDB	5,000 -16,000	32 - 106	30K/40K/50K	T2, T3, T4, T5	120-347V	UPM ships included	Dark Bronze	*292P6U	00198934597748	21
EAX2 ALO SWW2 SO UVOLT UPM PER DDB	18,000 - 30,000	112 - 213	30K/40K/50K	T2, T3, T4, T5	120-347V	UPM ships included	Dark Bronze	*292P7G	00198934597946	24

Note: Not all EAX configurations or options are included in the Contractor Select program. More configurations are available. Visit www.acuitybrands.com.

Accessories: Order as separate catalog number.						
Catalog	Description	Finish	CI Code	UPC	Pallet Qty	
EAX UPM DDB M6	Universal tilt arm square/round & pole top tenon mount	Dark Bronze	*292P92	00198934598424	240	
EAX SRA DDB M6	Standard square and round pole arm	Dark Bronze	*292P95	00198934598431	240	
EAX IS DDB M6	Adjustable slipfitter	Dark Bronze	*292P9E	00198934598530	360	
EAX ASRP DDB M6	Adjustable tilt square and round pole arm	Dark Bronze	*292P9G	00198934598547	270	
EAX WBA DDB M6	Wall bracket adapter	Dark Bronze	*292P9H	00198934598554	270	
EAX YK DDB M6	Adjustable yoke	Dark Bronze	*292P9J	00198934598561	300	
EAX1HSEGSBL M6	EAX1 House side and external glare shield kit	Black Finish	*292PAT	00198934598950	960	
EAX2HSEGSBL M6	EAX2 House side and external glare shield kit	Black Finish	*292PAW	00198934598981	378	



Specifications

INTENDED USE:

The EAX offers a complete area lighting package providing everything needed to replace 50W to 1000W HID area luminaires. This highly versatile luminaire features switchable technology including lumens, CCT and optics switching, allowing greater flexibility while helping reduce inventory costs. EAX is a great choice for new and retrofit pole mount applications exterior area lighting, parking lots, storage areas, retail and office spaces.

CONSTRUCTION:

Die-cast aluminum housing with heat-dissipating fins enhances LED efficacy and component life. Driver is accessible through a hinged die-cast aluminum door for easy maintenance. The light engine and driver compartment is completely sealed against moisture and environmental contaminants and rated IP66. The low-profile design results in a low EPA. EAX is rated for minimum 1.5 G vibration load per ANSI C136.31.

ELECTRICAL:

Light engine consists of high-efficiency LEDs mounted to metal-core circuit boards to maximize heat dissipation and promote long life (up to L74/100,000 hours at 25°C). The 0-10V dimming, electronic driver has a power factor of >90% and THD <20%. Standard 6KV surge protection.

INSTALLATION:

EAX offers a multi-use versatile adjustable tilt mounting arm that mounts to 3.0" min. O.D. round and 3.5" min. square poles and slip fits onto 2 3/8" pole top tenons. No-drill feature accommodates pre-existing pole drillings from 4.63" through 5.52" on center.

LISTINGS:

UL Listed to U.S. and Canadian safety standards for wet locations and IP66. Tested in accordance with IESNA LM-79 and LM-80 standards. Operating temperature -40C to 40C. DesignLights Consortium® (DLC) Premium qualified product. Not all versions of this product may be DLC Premium qualified. Please check the DLC Qualified Products List at www.designlights.org/QPL to confirm which versions are qualified.

WARRANTY:

5-year limited warranty. This is the only warranty provided and no other statements in this specification sheet create any warranty of any kind. All other express and implied warranties are disclaimed. Complete warranty terms located at: www.acuitybrands.com/support/warranty/terms-and-conditions.

Note: Actual performance may differ as a result of end-user environment and application. All values are design or typical values, measured under laboratory conditions at 25 °C. Specifications subject to change without notice.

Dimensions

All dimensions are inches (centimeters) unless otherwise indicated.

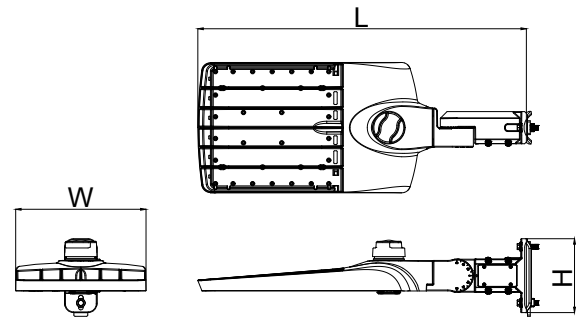

Luminaire	Length (L)	Width (W)	Height (H) Max.	Weight	EPA
EAX1	29.8" (75.7 cm)	11.8" (30.0 cm)	6.7" (17.0 cm)	14 lbs (6.4 kg)	0.49 ft2 (0.05 m2)
EAX2	35.0" (90.0 cm)	13.9" (35.3 cm)	6.7" (17.0 cm)	19 lbs (8.6 kg)	0.65 ft2 (0.06 m2)

