

UNIVERSAL VOLTAGE POWER PACK

| BZ-50

High-efficiency switching
power supply

Plenum rated

Zero crossing for reliability
and increased product life

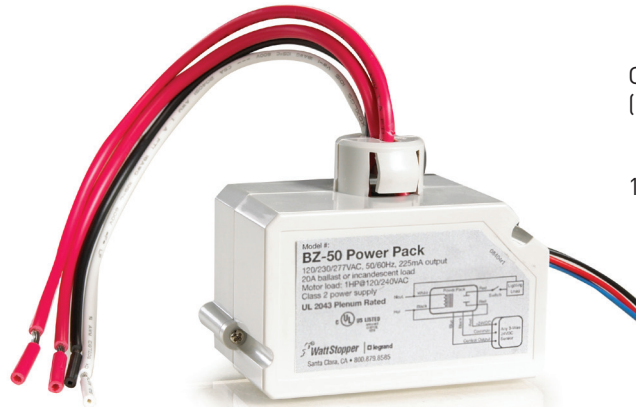

Overcurrent protection
(low-voltage)

120/277VAC, 50/60Hz



Description

The BZ-50 Universal Voltage Power Pack provides 24 VDC operating voltage to Wattstopper's low-voltage occupancy sensors. This device is constructed with environmentally friendly materials and is RoHS-compliant.

Operation

The BZ-50 consists of a high-efficiency switching power supply and a high-current relay. It has an input of 120/277 VAC, 50/60Hz, and an output of 24VDC, 225mA. It turns the connected load on and off automatically based on occupancy sensor input.

Features

- Self-contained power supply relay system
- Efficient switching power supply providing optimized current output based on number of sensors
- LED indicates status of relay or if there is a low-voltage overcurrent
- The product meets the materials restrictions of RoHS
- Zero crossing circuitry for reliability and increased product life

Plenum Rated

The BZ-50 Power Pack is comprised of Teflon-coated low-voltage leads and an ABS, UL 2043 and 94V-0 plastic resin enclosure that is plenum-rated. As a result, the BZ-50 does not require installation into the junction box, but can be cost-effectively installed directly into the plenum.

Applications

The BZ-50 Power Pack is designed to be flexible enough to control almost any lighting or HVAC load, such as lighting circuits, self-contained air conditioners, pumps, fans, motors, VAV systems, motorized damper controls and setback thermostats. The BZ-50 is well-suited for any application which requires high-voltage switching through low-voltage controls. By linking power packs and sensors, an almost unlimited number of configurations can be obtained.

- UL 2043 plenum rated for cost-effective installation
- 1/2" snap-in nipple attaches to standard electrical enclosures through 1/2" knockouts
- 14 AWG wires on the relay for 20A operation
- BAA/TAA-compliant models available

PROJECT	LOCATION/ TYPE
---------	-------------------

Specifications

- 120/277VAC, 50/60Hz voltage input
- Secondary voltage of 24 VDC
- Secondary output of 225 mA (with relay connected)
- Low-voltage leads are rated for 300 volts
- UL-rated 94 V-0 grey plastic enclosure
- Dimensions: 1.6" x 2.75" x 1.6" (40.6mm x 69.9mm x 40.6mm) H x W x D with a 1/2" (12.7mm) snap-in nipple
- UL and cUL listed
- Five year warranty

Installation and Wiring

Installation Diagram

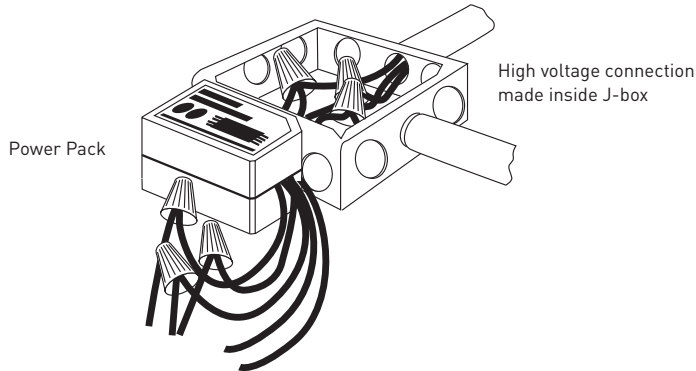

Wiring with Occupancy Sensor

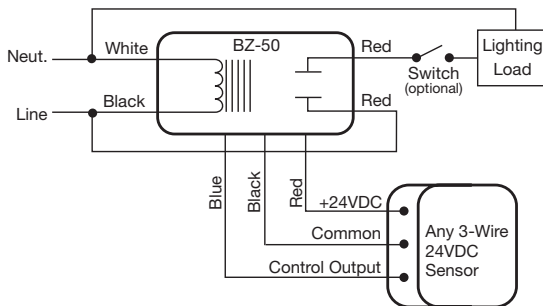

Auxiliary Relay Pack with Sensor

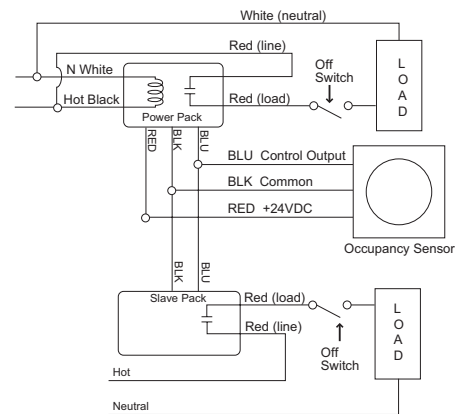

Ordering Information

Catalog #	Input Voltage	Load Ratings			Output
		Ballast(A)	Incan(A)	Motor(HP)	
<input type="checkbox"/> BZ-50	120/277VAC; 50/60Hz	20	20	1*	24 VDC; 225 mA**
<input type="checkbox"/> BZ-50-U					

*1 Hp rated at 120/250 VAC. **Output is 225 mA with relay connected.

-U = BAA/TAA compliant. Product is compliant with Buy American Act and Trade Agreement Act

1. All Wattstopper power packs should be installed in accordance with state, local, and national electrical codes and requirements.
2. Power packs are designed to attach to existing or new electrical enclosures with .5" 125.40mmJ knockout (check electrical codes in your area).
3. Most applications require UL-listed, 18-22 AWG, 3-conductor, Class 2 cables for low-voltage wiring. For plenum return ceilings use UL-listed plenum-approved cables.