

## Channels and Concrete Inserts

---

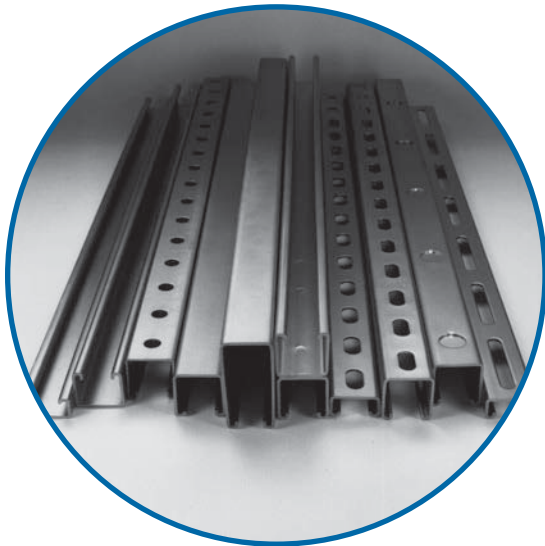

### Channels

#### Material

Steel channels are cold-roll formed from strip steel. Aluminum and Fiberglass channels are extruded profiles.

#### Material Thickness

All Series 1200	12 gauge material
All Series 1400	14 gauge material
All Series 1600	16 gauge ribbed material

#### Standard Lengths

Standard lengths for channels are 10 ft. and 20 ft. with a tolerance of +1/8 in. Special lengths can be requested; however, minimum quantities may apply. Channels are sold per foot.

### Warning

---

**Load tables, charts, and design criteria provided in this catalogue are intended as guides only. Selection of proper product, support spacing, erection, and placement are the responsibility of the user.**

**When improperly used as tools of erection, pipe hanger products have occasionally failed. To avoid an accident, the user is cautioned to use the product only as it was intended.**

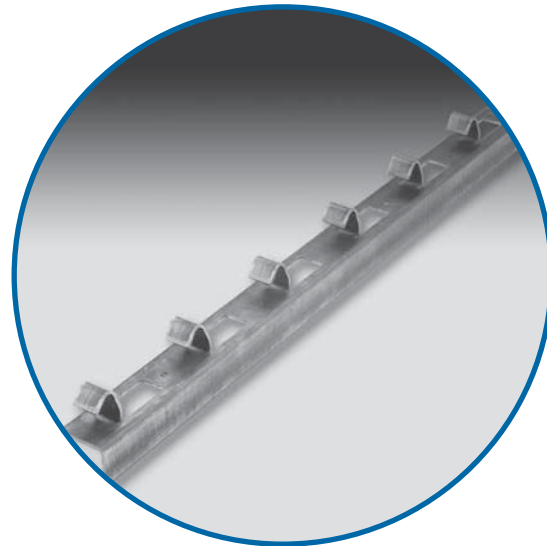

### Concrete Inserts

#### Material

Superstrut continuous insert channel is manufactured from 12 gauge hot rolled strip steel in two basic sizes as follows:

#### Cat. No. A302

1-5/8 in. x 1-5/8 in. 7/8 in. slot

#### Cat. No. C302

1-5/8 in. x 1-3/8 in. 7/8 in. slot

#### Standard Lengths

Standard lengths are 10 ft. and 20 ft. Product is supplied with foam filler and end caps to prevent concrete from seeping into channel.

#### Application

For casting into concrete walls, floors or ceilings to provide for attachment anywhere along the continuous slot.

#### Design Data

Load ratings as shown have a safety factor of 3 in 3000 lb. hard rock concrete. Where sound concrete does not exist, the load ratings shall not apply.

GoldGalv® hardware finish is standard for all Superstrut Concrete insert products. This is a multi-process finish of electro-plated zinc, followed by gold coloured zinc dichromate to give excellent corrosion resistance and a superior paint base.

For more information on load design, see page A57 for Engineering Data and Specifications.

## Channels and Concrete Inserts

**Channels at Full Scale**  
Available in 10 and 20 foot length

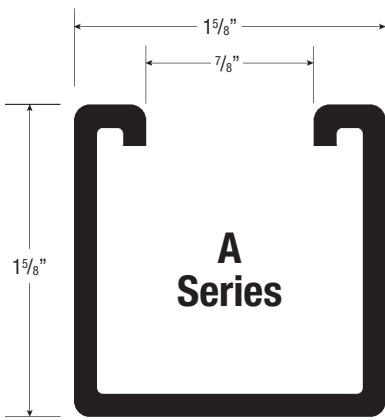

**A Series**  
A1200 12 gauge  
A1400 14 gauge

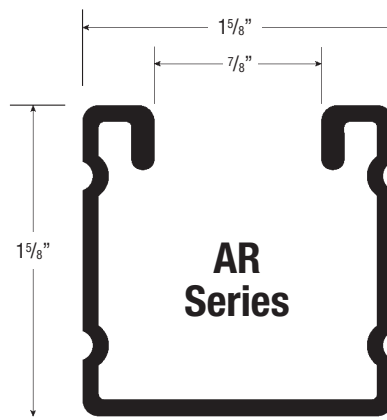

**AR Series**  
16 gauge only

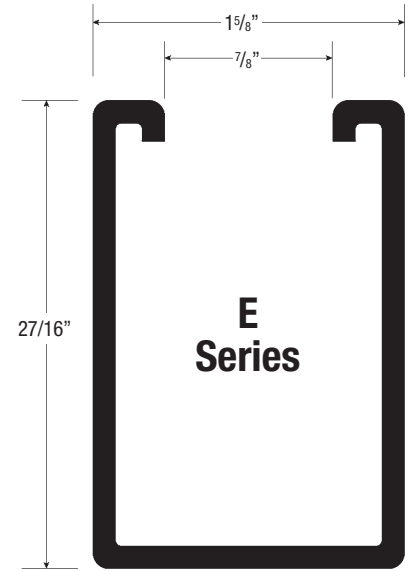

**E Series**  
E1200 12 gauge

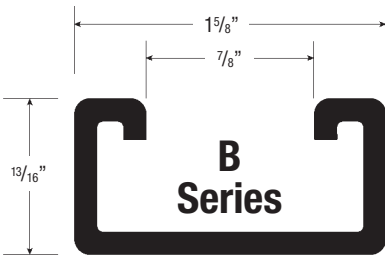

**B Series**  
B1200 12 gauge  
B1400 14 gauge

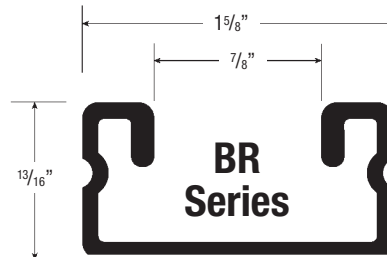

**BR Series**  
16 gauge only

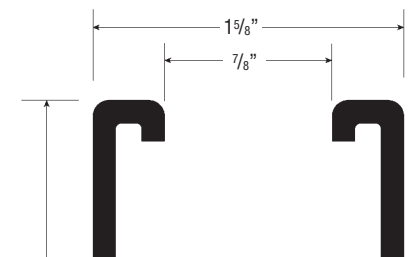

**H Series**  
H1200 12 gauge

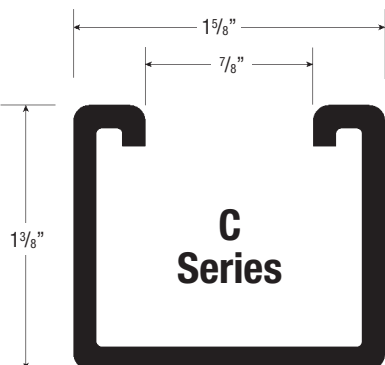

**C Series**  
C1200 12 gauge

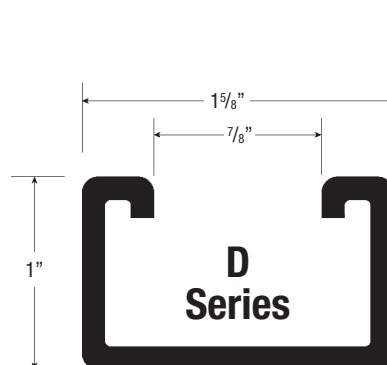

**D Series**  
D1200 12 gauge

## Channels and Concrete Inserts

### Channel Selection Chart

CHANNEL	HOLE CONFIGURATIONS					LENGTH	FINISH ON STEEL						SPECIAL MATERIALS			
	HS	S	SW	P	KO		ft.	B(C)	PG(C)	EG(C)	GoldGalv®	HDG(C)	GR(C),GY(C),WH(C)	AL(C)	T316L	SS6(C)
A1200						10 or 20										
A1400						10 or 20										
AR1600						10 or 20										
B1200						10 or 20										
B1400						10 or 20										
BR1600						10 or 20										
C1200						10 or 20										
D1200						10 or 20										
E1200						10 or 20										
H1200						10 or 20										

### Legend

EXAMPLES	HOLE CONFIGURATION		FINISH ON STEEL		SPECIAL MATERIALS	
	Suffix		Suffix		Suffix	
<b>A120010PG</b> Plain channel, 10 ft., pre- galvanized finish	<b>blank</b>	Plain, no holes	<b>BC</b>	Bare	<b>AL</b>	Aluminum
	<b>HS</b>	Half slot	<b>PGC</b>	Pre-galvanized	<b>SS6 (C)</b>	Stainless Steel Type 316
<b>B1400P10</b> Punched channel, 10 ft., GoldGalv® finish	<b>S</b>	Slotted	<b>EGC</b>	Electrogalvanized	<b>T316L</b>	Stainless Steel Type 316L
	<b>SW</b>	Slotted wide	<b>Blank</b>	GoldGalv®		
	<b>P</b>	Punched	<b>HDGC</b>	Hot dipped galvanized		
<b>E1200HS20HDG</b> Half slot channel, 20 ft. hot dipped galvanized	<b>KO</b>	Knockout	<b>GR,GY,WH</b>	Epoxy paint in green (GR), grey (GY), or white (WH)		
		Standard offering		A minimum order quantity may apply		

### Hole Configuration

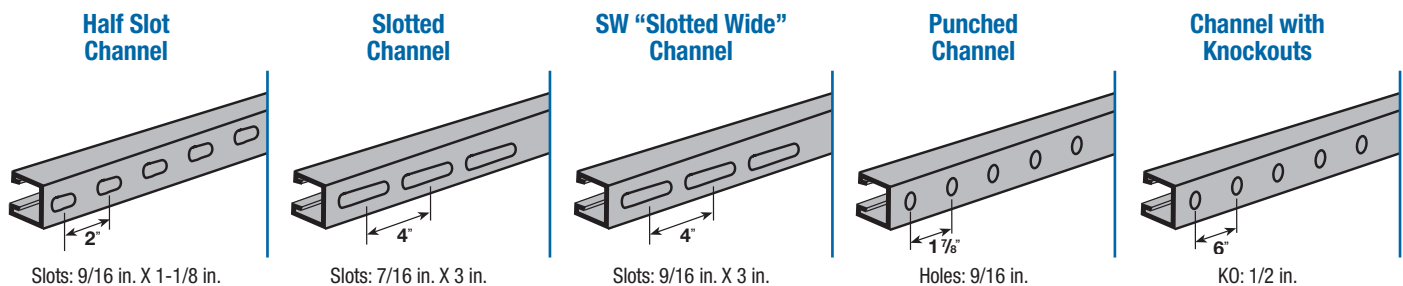

## Channels and Concrete Inserts

### Welded Combinations

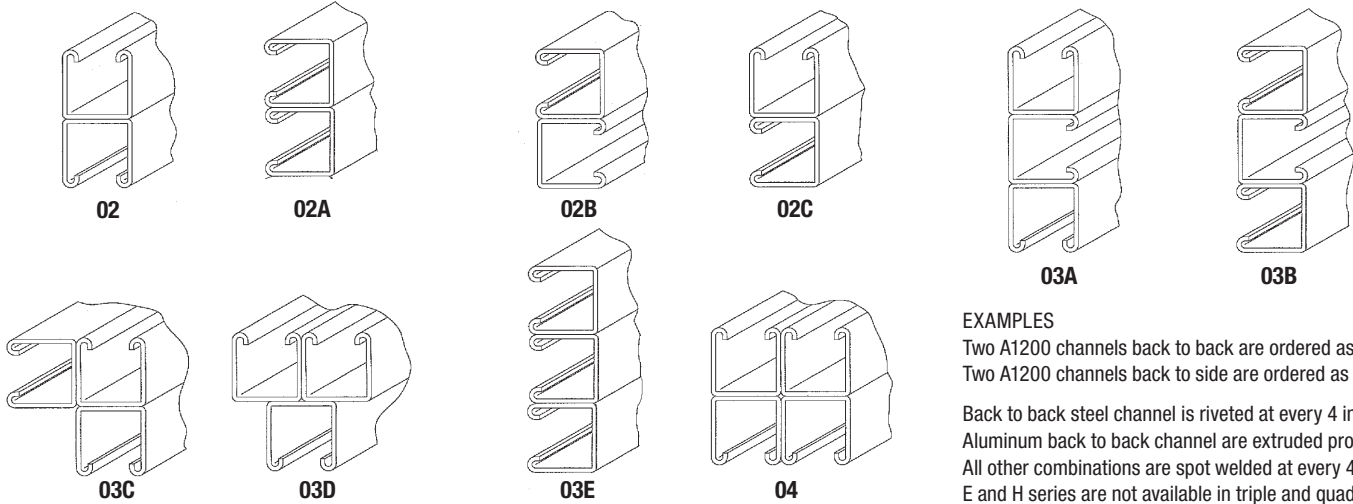

#### EXAMPLES

Two A1200 channels back to back are ordered as A1202.  
Two A1200 channels back to side are ordered as A1202C.  
Back to back steel channel is riveted at every 4 inches.  
Aluminum back to back channel are extruded profiles.  
All other combinations are spot welded at every 4 inches.  
E and H series are not available in triple and quadruple.

### End Caps and Closure Strips

#### A804 End Cap

#### RAWSEC End Cap for D1200 Channel

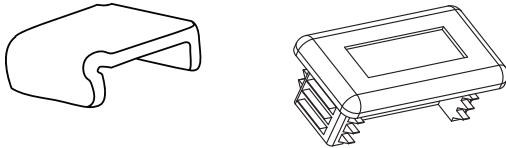

Cat. No.	For Channel	Wt./C lb.
A804EG	A1200	10
	A1400 AR1600	10
B804EG	B1400 BR1600	5
C804EG	C1200	8
E804EG	E1200	15
H804	H1400	20
RAWSEC	D1200	5 g (0.18 oz)

### Safety End Cap

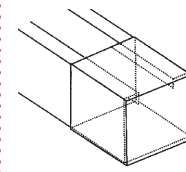

1-5/8 in. x 1-5/8 in. White Plastisol

Cat. No.	For Channel	Wt./C lb.
A804NEOPWH	A1200 AR1600	1.75
	A1400	
B804NEOPWH	B1200 BR1600	5
H804NEOPWH	H1200	2

### A243-1EGC End Cap

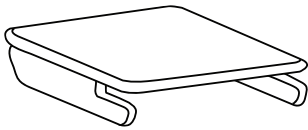

For A1200 Channel  
Wt./C 16 lb.

### A208

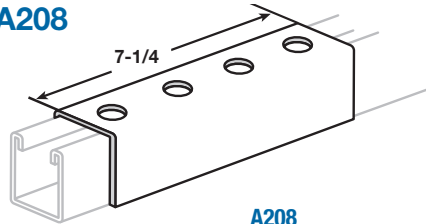

A208HDGC  
A208EG

Does not include stud nut or bolts.

A208  
A208SS6C

Pour profilés des séries A et AR.  
Poids/100 : 275 lb

### A213 Inside Joiner

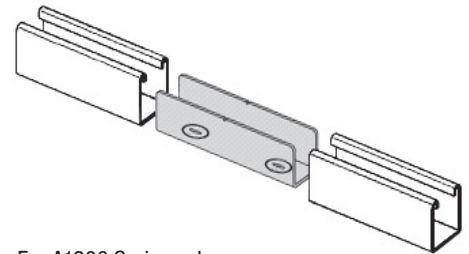

For A1200 Series only.  
Available only in GoldGalv® finish.

### Pre-Galvanized Steel Closure Strip

AB844PGC  
AB844PGCWH  
White Epoxy Powder Coated

### Plastic Closure Strip

AB844PC Color : Gold  
AB844PCGY Color : Grey

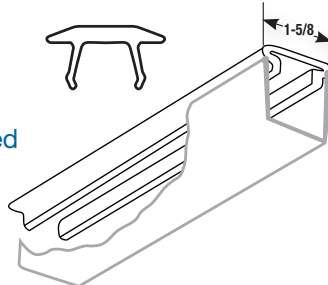

- When used as a raceway, channel is normally installed with the slot up. After wiring has been completed the closure strip is installed.
- For all channels.
- Standard length: 10 ft.

### Stainless Steel Closure Strip

AB844SS6CS (Strapping not included)

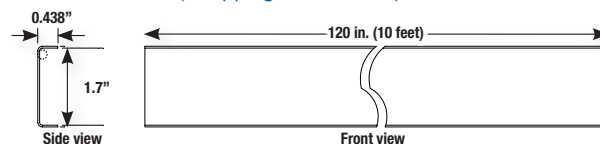

## Channels and Concrete Inserts

### Concrete inserts

#### Concrete Channel Inserts

**\*Finishes**

- HDGC
- GoldGalv®
- PGC

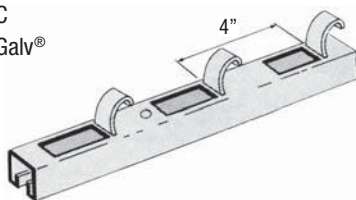

Insert with end caps and foam closure strip installed.

Cat. No.	Length (ft.)	Gauge	Wt. (lb./ft.)
A302-10*	10	12	2.19
A302-20*	20		2.19
B302-10*	10		1.36
B302-20*	20		1.36

Design Load 2000 lb. per foot in hard rock concrete with a safety factor of 3.

Standard lengths: 10 ft. and 20 ft.

Length tolerance: 3/16 in.

#### Anchor Caps

**\*Finishes**

- EGC
- GoldGalv®

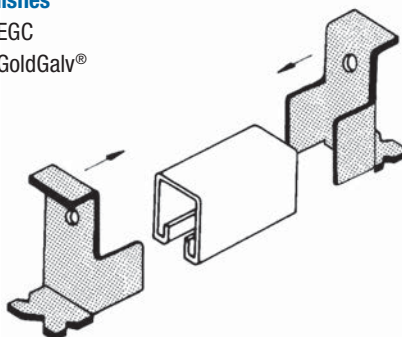

12 gauge, Wt./C: 30 lb./C

A450\* For A Series

C450\* For C Series

From pieces of A, B, C channel and a pair of anchor caps, short concrete inserts can be fabricated in the field.

#### 460-10TB Removable Plastic Closure Strip

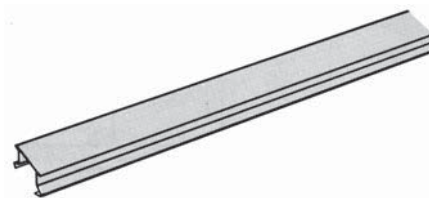

Designed as an added precaution to keep insert free of concrete. Closure strip fits all 1-5/8 in. wide strip inserts, regardless of depth.

Order per 10 foot, standard length is 10 ft.

Material – Black Plastic

Wt./C 52 lb.

#### SI400 Spot Insert Kit

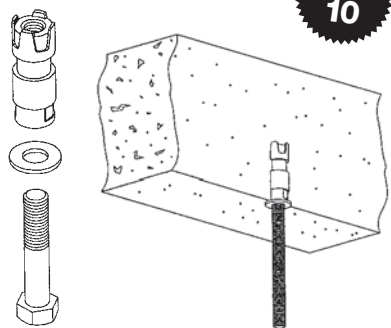

Cat. No.	Thred size	O.D. Insert	Wt./C lb.
SI400-3/8	3/8 – 16	2x5/8	10
SI400-1/2	1/2x13x1-1/4	2-1/2x7/8	35

Other sizes available.

Maximum recommended load:

SI400-3/8 = 450 lb./204 kg

SI400-1/2 = 1000 lb./454 kg

#### 452TB Spot Insert

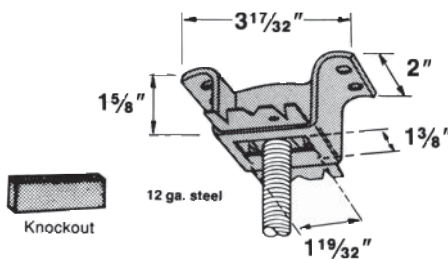

**Standard Finish – GoldGalv®**

An insert with a knockout saves covering the opening. Accommodates hanger rod sizes from 1/4 in. through 7/8 in. by means of an AB102 insert nut, to be ordered separately.

**Design load:** 1350 lb. in 3000 lb. hard rock concrete with a safety factor of 3.

Complies with Specification MSS SP69, Type 18.

## Channels and Concrete Inserts

---

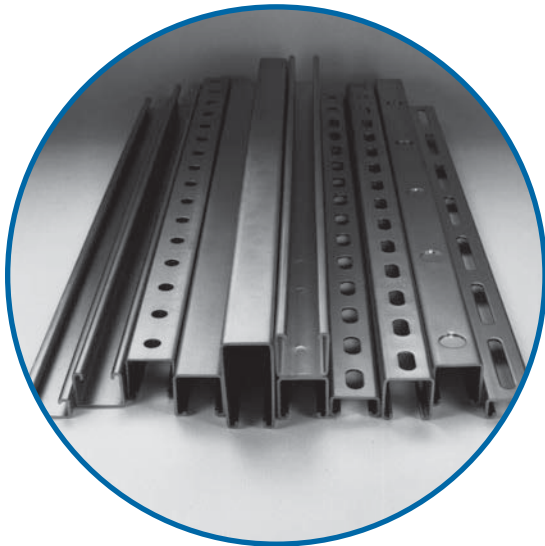

### Channels

#### Material

Steel channels are cold-roll formed from strip steel. Aluminum and Fiberglass channels are extruded profiles.

#### Material Thickness

All Series 1200	12 gauge material
All Series 1400	14 gauge material
All Series 1600	16 gauge ribbed material

#### Standard Lengths

Standard lengths for channels are 10 ft. and 20 ft. with a tolerance of +1/8 in. Special lengths can be requested; however, minimum quantities may apply. Channels are sold per foot.

### Warning

---

**Load tables, charts, and design criteria provided in this catalogue are intended as guides only. Selection of proper product, support spacing, erection, and placement are the responsibility of the user.**

**When improperly used as tools of erection, pipe hanger products have occasionally failed. To avoid an accident, the user is cautioned to use the product only as it was intended.**

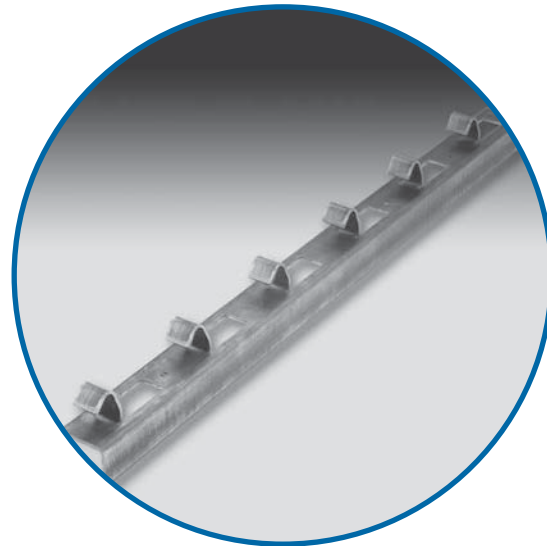

### Concrete Inserts

#### Material

Superstrut continuous insert channel is manufactured from 12 gauge hot rolled strip steel in two basic sizes as follows:

#### Cat. No. A302

1-5/8 in. x 1-5/8 in. 7/8 in. slot

#### Cat. No. C302

1-5/8 in. x 1-3/8 in. 7/8 in. slot

#### Standard Lengths

Standard lengths are 10 ft. and 20 ft. Product is supplied with foam filler and end caps to prevent concrete from seeping into channel.

#### Application

For casting into concrete walls, floors or ceilings to provide for attachment anywhere along the continuous slot.

#### Design Data

Load ratings as shown have a safety factor of 3 in 3000 lb. hard rock concrete. Where sound concrete does not exist, the load ratings shall not apply.

GoldGalv® hardware finish is standard for all Superstrut Concrete insert products. This is a multi-process finish of electro-plated zinc, followed by gold coloured zinc dichromate to give excellent corrosion resistance and a superior paint base.

For more information on load design, see page A57 for Engineering Data and Specifications.

## Channels and Concrete Inserts

**Channels at Full Scale**  
Available in 10 and 20 foot length

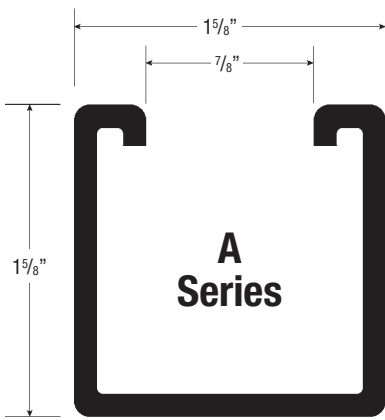

**A Series**  
A1200 12 gauge  
A1400 14 gauge

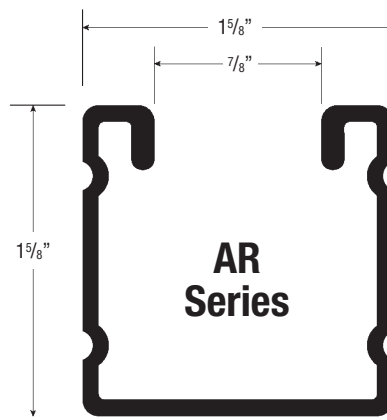

**AR Series**  
16 gauge only

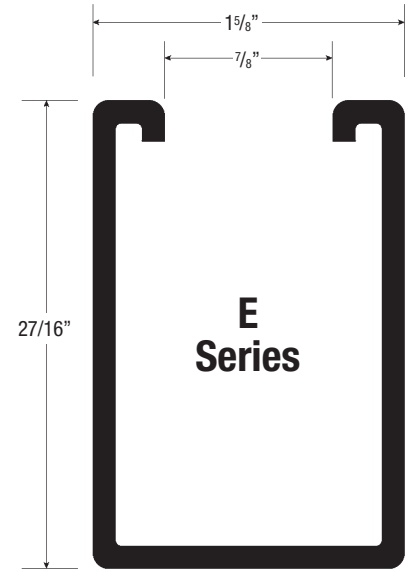

**E Series**  
E1200 12 gauge

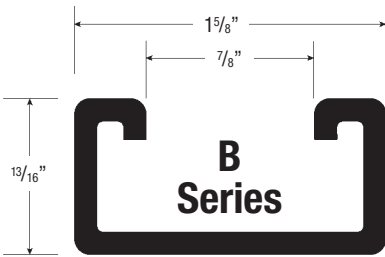

**B Series**  
B1200 12 gauge  
B1400 14 gauge

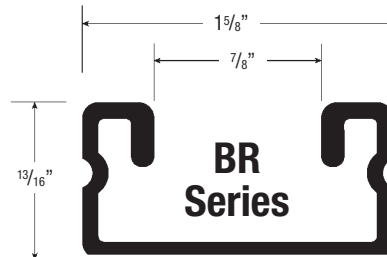

**BR Series**  
16 gauge only

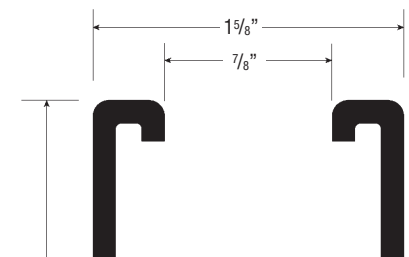

**H Series**  
H1200 12 gauge

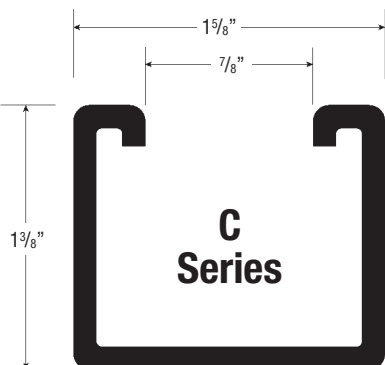

**C Series**  
C1200 12 gauge

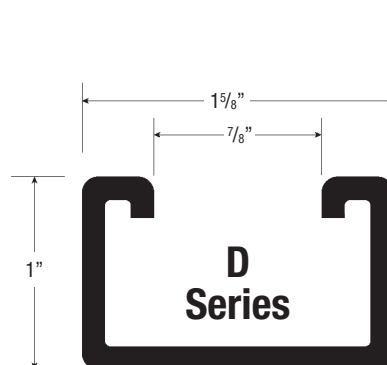

**D Series**  
D1200 12 gauge

## Channels and Concrete Inserts

### Channel Selection Chart

CHANNEL	HOLE CONFIGURATIONS					LENGTH	FINISH ON STEEL						SPECIAL MATERIALS			
	HS	S	SW	P	KO		ft.	B(C)	PG(C)	EG(C)	GoldGalv®	HDG(C)	GR(C),GY(C),WH(C)	AL(C)	T316L	SS6(C)
A1200						10 or 20										
A1400						10 or 20										
AR1600						10 or 20										
B1200						10 or 20										
B1400						10 or 20										
BR1600						10 or 20										
C1200						10 or 20										
D1200						10 or 20										
E1200						10 or 20										
H1200						10 or 20										

### Legend

EXAMPLES	HOLE CONFIGURATION		FINISH ON STEEL		SPECIAL MATERIALS	
	Suffix		Suffix		Suffix	
<b>A120010PG</b> Plain channel, 10 ft., pre-galvanized finish	<b>blank</b>	Plain, no holes	<b>BC</b>	Bare	<b>AL</b>	Aluminum
	<b>HS</b>	Half slot	<b>PGC</b>	Pre-galvanized	<b>SS6 (C)</b>	Stainless Steel Type 316
<b>B1400P10</b> Punched channel, 10 ft., GoldGalv® finish	<b>S</b>	Slotted	<b>EGC</b>	Electrogalvanized	<b>T316L</b>	Stainless Steel Type 316L
	<b>SW</b>	Slotted wide	<b>Blank</b>	GoldGalv®		
	<b>P</b>	Punched	<b>HDGC</b>	Hot dipped galvanized		
<b>E1200HS20HDG</b> Half slot channel, 20 ft. hot dipped galvanized	<b>KO</b>	Knockout	<b>GR,GY,WH</b>	Epoxy paint in green (GR), grey (GY), or white (WH)		
		Standard offering		A minimum order quantity may apply		

### Hole Configuration

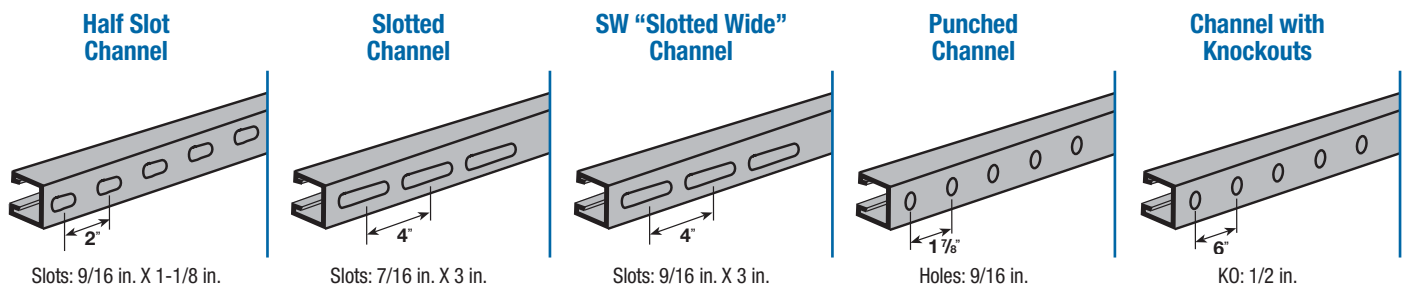



## Channels and Concrete Inserts

### Welded Combinations

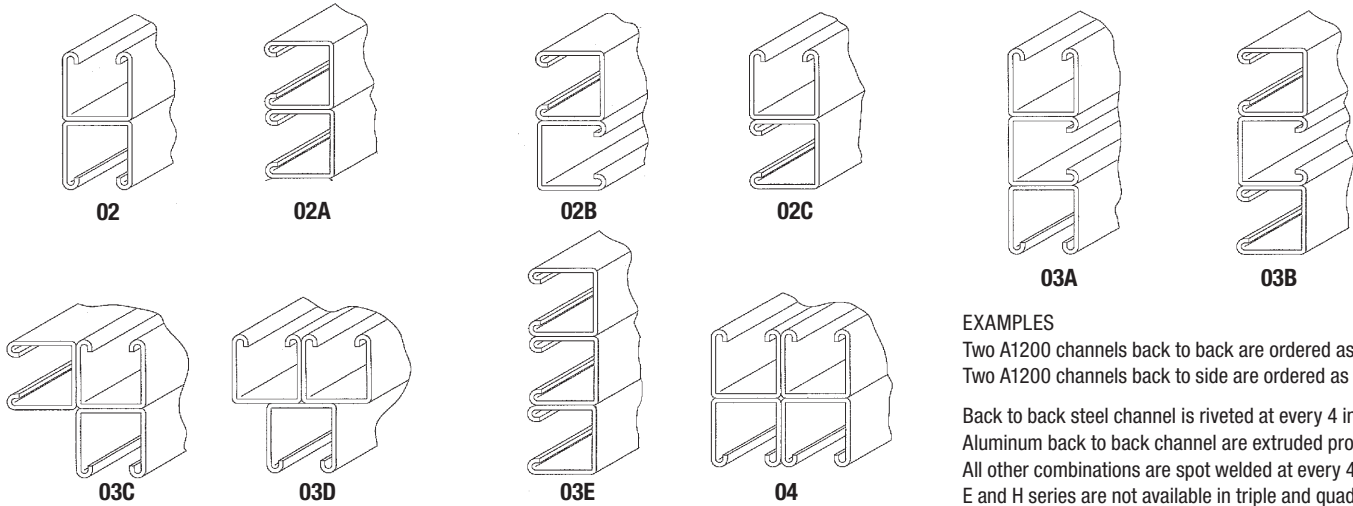

#### EXAMPLES

Two A1200 channels back to back are ordered as A1202.  
Two A1200 channels back to side are ordered as A1202C.

Back to back steel channel is riveted at every 4 inches.  
Aluminum back to back channel are extruded profiles.  
All other combinations are spot welded at every 4 inches.  
E and H series are not available in triple and quadruple.

### End Caps and Closure Strips

#### A804 End Cap

#### RAWSEC End Cap for D1200 Channel

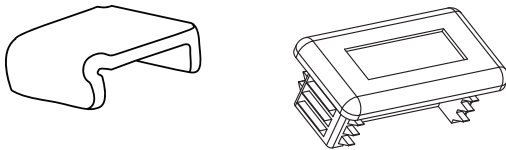

Cat. No.	For Channel	Wt./C lb.
A804EG	A1200	10
	A1400 AR1600	10
B804EG	B1400 BR1600	5
C804EG	C1200	8
E804EG	E1200	15
H804	H1400	20
RAWSEC	D1200	5 g (0.18 oz)

### Safety End Cap

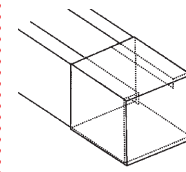

1-5/8 in. x 1-5/8 in. White Plastisol

Cat. No.	For Channel	Wt./C lb.
A804NEOPWH	A1200 AR1600	1.75
	A1400	
B804NEOPWH	B1200 BR1600	5
H804NEOPWH	H1200	2

### A243-1EGC End Cap

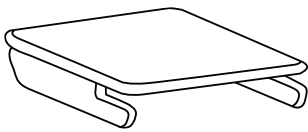

For A1200 Channel  
Wt./C 16 lb.

### A208

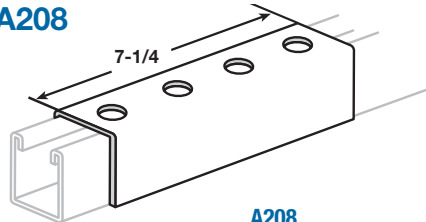

A208HDGC  
A208EG

Does not include  
stud nut or bolts.

A208  
A208SS6C

Pour profilés  
des séries A et AR.  
Poids/100 : 275 lb

### A213 Inside Joiner

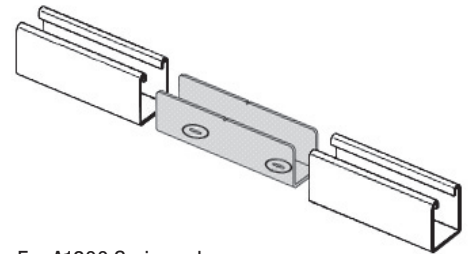

For A1200 Series only.  
Available only in GoldGalv® finish.

### Pre-Galvanized Steel Closure Strip

AB844PGC  
AB844PGCWH  
White Epoxy Powder Coated

### Plastic Closure Strip

AB844PC Color : Gold  
AB844PCGY Color : Grey

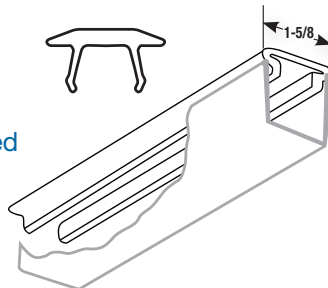

- When used as a raceway, channel is normally installed with the slot up. After wiring has been completed the closure strip is installed.
- For all channels.
- Standard length: 10 ft.

### Stainless Steel Closure Strip

AB844SS6CS (Strapping not included)

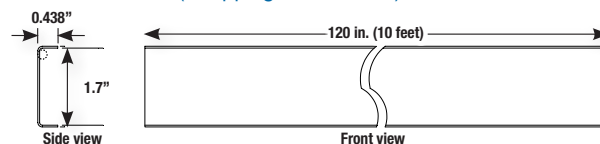

## Channels and Concrete Inserts

### Concrete inserts

#### Concrete Channel Inserts

**\*Finishes**

- HDGC
- GoldGalv®
- PGC

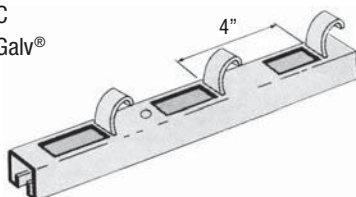

Insert with end caps and foam closure strip installed.

Cat. No.	Length (ft.)	Gauge	Wt. (lb./ft.)
A302-10*	10	12	2.19
A302-20*	20		2.19
B302-10*	10		1.36
B302-20*	20		1.36

Design Load 2000 lb. per foot in hard rock concrete with a safety factor of 3.

Standard lengths: 10 ft. and 20 ft.

Length tolerance: 3/16 in.

#### Anchor Caps

**\*Finishes**

- EGC
- GoldGalv®

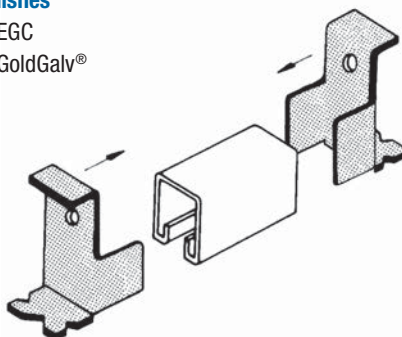

12 gauge, Wt./C: 30 lb./C

A450\* For A Series

C450\* For C Series

From pieces of A, B, C channel and a pair of anchor caps, short concrete inserts can be fabricated in the field.

#### 460-10TB Removable Plastic Closure Strip

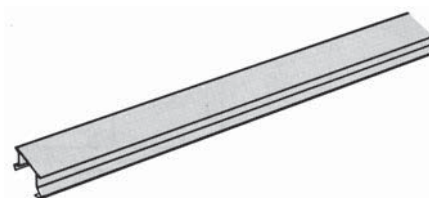

Designed as an added precaution to keep insert free of concrete. Closure strip fits all 1-5/8 in. wide strip inserts, regardless of depth.

Order per 10 foot, standard length is 10 ft.

Material – Black Plastic

Wt./C 52 lb.

#### SI400 Spot Insert Kit

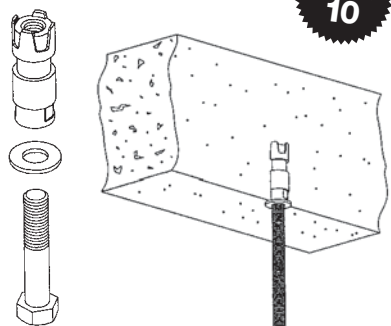

Cat. No.	Thred size	O.D. Insert	Wt./C lb.
SI400-3/8	3/8 – 16	2x5/8	10
SI400-1/2	1/2x13x1-1/4	2-1/2x7/8	35

Other sizes available.

Maximum recommended load:

SI400-3/8 = 450 lb./204 kg

SI400-1/2 = 1000 lb./454 kg

#### 452TB Spot Insert

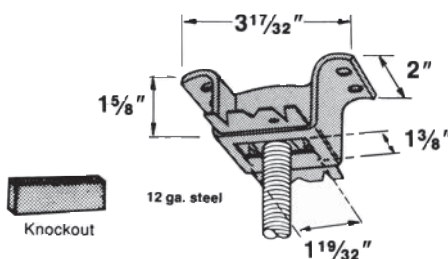

**Standard Finish – GoldGalv®**

An insert with a knockout saves covering the opening. Accommodates hanger rod sizes from 1/4 in. through 7/8 in. by means of an AB102 insert nut, to be ordered separately.

**Design load:** 1350 lb. in 3000 lb. hard rock concrete with a safety factor of 3.

Complies with Specification MSS SP69, Type 18.